



Board of Public Works and Safety

Agenda Item

Cover Sheet

MEETING DATE: May 14, 2024

- Consent Agenda Item
- New Item for Discussion
- Previously Discussed Item
- Miscellaneous

ITEM #: 7

INITIATED BY: Jonathan Mirgeaux

- Information Attached
- Bring Paperwork from Previous Meeting
- Verbal
- No Paperwork at Time of Packets

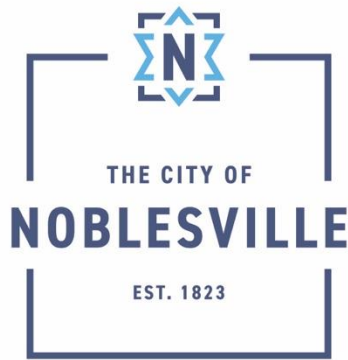

TO: Noblesville Board of Public Works and Safety
FROM: Jonathan Mirgeaux, Utilities Director
SUBJECT: Board to Consider Services Agreement with American Structurepoint, Inc.
DATE: May 14, 2024

The Utilities is requesting approval of a Services Agreement with American Structurepoint, Inc. in the amount of \$108,900 to increase capacity at Lift Station 2 to accommodate growth in Wayne Township.

The scope of services is to prepare construction documents for the following:

- approximately 1400 linear feet of 48" diameter sewer upstream of Lift Station 2
- increased pumping capacity at Lift Station 2

The new 48" sewer will relieve the currently undersized 27" sewer upstream of the lift station that receives flow from the Stony Creek Interceptor (42"). Old Town Noblesville (27"), and the Wellington Northeast Neighborhood (15").

The replacement pumps for Lift Station 2 have already been sized and their purchase was approved by the Board on 12/19/23. Delivery is scheduled for August 2024. The American Structurepoint, Inc. design will support the installation process, providing precise placement locations, necessary piping and valving, and other accoutrements.

We request the Board approve the Services Agreement with American Structurepoint, Inc.



SERVICES AGREEMENT

This Services Agreement (hereinafter referred to as “Agreement”), entered into by and between the **City of Noblesville, Indiana, a municipal corporation** (hereinafter referred to as “City”) and **American Structurepoint, Inc.**, hereinafter referred to as “Contractor”), and its successors and assigns, is executed pursuant to the terms and conditions set forth herein. In consideration of those mutual undertakings and covenants, the parties agree as follows:

SECTION I. INTERPRETATION AND INTENT

- 1.1 The “Agreement”, as referred to herein, shall mean this Agreement executed by City and Contractor, and shall include this Services Agreement and the **Exhibit A** attached hereto, and any written supplemental agreement or modification entered into between City and Contractor, in writing, after the date of this Agreement.
- 1.2 This Agreement constitutes the entire agreement between the parties and supersedes all prior agreements, written or verbal, between City and Contractor. No statements, promises or agreements whatsoever, in writing or verbal, in conflict with the terms of the Agreement have been made by City or Contractor which in any way modify, vary, alter, enlarge or invalidate any of the provisions and obligations herein stated. This Agreement may be amended and modified only in writing signed by both City and Contractor.
- 1.3 In resolving conflicts, errors, discrepancies and disputes concerning the scope of the work or services to be performed by Contractor or other rights or obligations of City or Contractor the document or provision thereof expressing the greater quantity, quality or scope of service or imposing the greater obligation upon Contractor and affording the greater right or remedy to City, shall govern.
- 1.4 Any interpretation applied to this Agreement, by the parties hereto, by an arbitrator, court of law, or by any other third party, shall not be made against City solely by virtue of City or City’s representatives having drafted all or any portion of this Agreement.
- 1.5 This Agreement shall include, and incorporate by reference, any provision, covenant or condition required or provided by law or by regulation of any state or federal regulatory or funding agency.

SECTION II. DUTIES OF CONTRACTOR

- 2.1 Contractor shall provide services as specified in **Exhibit A**, attached hereto and incorporated into this Agreement.

SECTION III. TERM

- 3.1 The term of this Agreement shall begin upon execution and terminate December 31st, 2026, (“Termination Date”) or when the services in **Exhibit A** have been completed, whichever is later, unless terminated earlier in accordance with this Agreement.

SECTION IV. COMPENSATION

- 4.1 Contractor proposes to furnish all labor, materials and supplies in accordance with the conditions of this Agreement necessary to complete the work as defined in Exhibit A. Compensation shall not exceed One Hundred Eight Thousand Nine Hundred Dollars (\$108,900)
- 4.2 Funding for a multi-year agreement is not guaranteed. All of the City's obligations under this Agreement shall be subject to annual appropriation and shall not constitute a general obligation or indebtedness of the City.

SECTION V. GENERAL PROVISIONS

- 5.1 Independent Contractor. The parties agree that Contractor is an independent contractor as that term is commonly used and is not an employee of the City. As such, Contractor is solely responsible for all taxes and none shall be withheld from the sums paid to Contractor. Contractor acknowledges that it is not insured in any manner by City for any loss of any kind whatsoever. Contractor has no authority, express or implied, to bind or obligate City in any way.
- 5.2 Subcontracting.
Approval required. The parties agree that Contractor shall not subcontract, assign or delegate any portion of this Agreement or the services to be performed hereunder without prior written approval of City. In the event that City approves of any such subcontracting, assignment or delegation, Contractor shall remain solely responsible for managing, directing and paying the person or persons to whom such responsibilities or obligations are sublet, assigned or delegated. City shall have no obligation whatsoever toward such persons. Contractor shall take sole responsibility for the quality and quantity of any services rendered by such persons. Any consent given in accordance with this provision shall not be construed to relieve Contractor of any responsibility for performing under this Agreement.
- 5.3 Necessary Documentation. N/A
- 5.4 Records; Audit. Contractor shall maintain books, records, documents and other evidence directly pertinent to performance of services under this Agreement. Contractor shall make such materials available at its offices at all reasonable times during the Agreement period copies thereof, if requested, shall be furnished at no cost to City.
- 5.5 Ownership.
 - 5.5.1 "Works" means works of authorship fixed in any tangible medium of expression by Contractor or its officers, employees, agents or subcontractors in the course of performing the services under this Agreement, including, but not limited to, computer programs, electronic art, computer generated art, notes, specifications, drawings, flow charts, memoranda, correspondence, records, notebooks,

documentation, reports and charts, regardless of the medium in which they are fixed, and all copies thereof.

5.5.2 All Works made or created by Contractor, either solely or jointly with City, in the course of Contractor's performance of services under this Agreement shall be deemed to be works for hire and are and shall be the exclusive property of City. At City's request, Contractor will execute all documents reasonably required to confirm or perfect ownership of such Works and any corresponding copyright rights in and to such Works in City. Without the prior written consent of City, Contractor shall not use, copy or prepare derivative works of the Works, or any parts of them, other than as related to the performance of this Agreement. During the performance of this Agreement, Contractor shall be responsible for loss or damage to the Works while they are in Contractor's possession or control. Any loss or damage shall be restored at Contractor's expense. City shall have free and unlimited access to the Works at all times and, upon demand, shall have the right to claim and take possession of the Works and all copies. Notwithstanding the foregoing, Contractor shall be entitled to retain a set of its work papers for archival purposes only, in accordance with applicable professional standards.

5.6 Insurance.

Minimum Insurance Requirements. Prior to commencing Work, the Contractor shall purchase and maintain from insurance companies lawfully authorized to do business in Indiana policies of insurance acceptable to the City, which afford the coverages set forth below. Insurance shall be written for not less than limits of liability specified or required by law, whichever coverage is greater, and shall include coverage for Contractor's indemnification obligations contained in this Agreement. Certificates of Insurance acceptable to the City shall be given to the City prior to commencement of the Work and thereafter upon renewal or replacement of each required policy of insurance. Each policy must be endorsed to provide that the policy will not be cancelled or allowed to expire until at least thirty (30) days' prior written notice has been given to the City; provided however that such policies may be cancelled with only ten (10) days' prior notice for non-payment of premium. The required coverages and limits which Contractor is required to obtain are as follows:

A. Commercial General Liability

Limits of Liability: \$2,000,000 General Aggregate
 \$2,000,000 Products & Completed Ops.
 \$1,000,000 Bodily Injury / Prop. Damage
 \$1,000,000 Personal / Advertising Injury
 \$1,000,000 Each Occurrence

B. Auto Liability

Limits of Liability: \$500,000 Per Accident

Coverage Details All owned, non-owned, & hired vehicles

C. Workers Compensation and Employer's Liability

As required by Indiana law.

D. Professional/Errors & Omissions Liability

Limits of Liability \$1,000,000 Each Occurrence
 \$2,000,000 Aggregate

All coverage provided above shall be endorsed to include the City as an additional insured except for the Worker's Compensation / Employer's Liability and Professional/Errors & Omissions policy.

5.7 Termination for Cause or Convenience.

- 5.7.1 If Contractor becomes insolvent, or if it refuses or fails to perform the work and services provided by this Agreement, or if it refuses to perform disputed work or services as directed pending resolution of such dispute, or if it fails to make payments to subcontractors employed by it, or if it otherwise violates or fails to perform any term, covenant or provision of this Agreement, then City may, without prejudice to any other right or remedy, terminate this Agreement in whole or in part, in writing, provided that Contractor shall be given (1) not less than ten (10) calendar days written notice of City's intent to terminate, and (2) an opportunity for consultation with City prior to termination. In determining the amount of final payment to be made to Contractor upon such termination for default, if any, no amount shall be allowed for anticipated profit on unperformed services or other work; furthermore, an adjustment shall be made to the extent of any additional costs incurred or reasonably foreseen by City to be incurred by reason of Contractor's default.
- 5.7.2 This Agreement may be terminated in whole or in part in writing by City for City's convenience; provided that Contractor is given (1) not less than ten (10) calendar days written notice of intent to terminate and (2) an opportunity for consultation with City prior to termination. If City terminates for convenience, Contractor's compensation shall be equitably adjusted.
- 5.7.3 Upon receipt of notice of termination for default or for City's convenience, Contractor shall (1) promptly discontinue all services affected, unless the termination notice directs otherwise, and (2) deliver or otherwise make available to City all Works and such other information, materials or documents as may have been accumulated by Contractor in performing this Agreement, whether completed or in process.
- 5.7.4 If, after termination for Contractor's default, it is determined that Contractor was not in default, the termination shall be deemed to have been made for the convenience of City. In such event, adjustment of the price provided for in this Agreement shall be made as provided in Section 5.7.1 and the recovery of such price adjustment shall be Contractor's sole remedy and recovery.

- 5.8 Termination for Failure of Funding. Notwithstanding any other provision of this Agreement, if funds for the continued fulfillment of this Agreement by City are at any time insufficient or not forthcoming through failure of any entity to appropriate funds or otherwise, then City shall have the right to terminate this Agreement without penalty by giving written notice documenting the lack of funding, in which instance this Agreement shall terminate and become null and void on the last day of the fiscal period for which appropriations were received. City agrees that it will make its best efforts to obtain sufficient funds, including but not limited to, requesting in its budget for each fiscal period during the term hereof sufficient funds to meet its obligations hereunder in full.
- 5.9 Indemnification. To the fullest extent permitted by law, the Contractor shall indemnify and hold harmless the City and its board, agents and employees of any of them (“Indemnitees”) from and against damages, losses and expenses, including but not limited to reasonable attorneys’ fees and court costs and other expenses but only to the extent caused by the negligent acts, errors, or omissions of the Contractor. The Contractor’s indemnification under this Section shall survive both final payment and the termination of this Agreement.
- 5.10 Notice. Any notice required to be sent under this Agreement shall be sent by internationally recognized overnight courier, certified mail, or other delivery method which provides confirmation of receipt and shall be directed to the persons and addresses specified below (or such other persons and/or addresses as any party may indicate by giving notice to the other party):

To Contractor:
American Structurepoint, Inc.
Attn: Cash E. Canfield
9025 River Road, Suite 200
Indianapolis, IN 46240

To City:
City of Noblesville
Attn: Jonathan Mirgeaux
16 S. 10th Street
Noblesville, IN 46060

Courtesy Copy:
City Attorney
16 S. 10th Street
Noblesville, IN 46060

- 5.11 Disputes. Contractor shall carry on all work required under this Agreement and maintain the schedule for services during all disputes or disagreements with City. No work shall be delayed or postponed pending resolution of any disputes or disagreements except as Contractor and City may otherwise agree in writing. Should Contractor fail to continue to perform its responsibilities as regards all non-disputed work without delay, any additional costs incurred by City or Contractor as a result of such failure to proceed shall be borne by Contractor, and Contractor shall make no claim against the City for such costs. City may withhold payments on disputed items pending resolution of the dispute.
- 5.12 Non-discrimination. The Contractor shall not discriminate against any employee or applicant for employment because of race, color, religion, sex, age or national origin.

The Contractor will take affirmative action to ensure that applicants are employed without regard to their race, color, religion, sex, age or national origin. Such action shall include, but not be limited to the following: employment, upgrading, demotion or transfer, recruitment or recruitment advertising, layoff or termination, rates of pay or other forms of compensation, and selection for training, including apprenticeship.

5.13 Conflict of Interest.

5.13.1 Contractor certifies and warrants to City that neither it nor any of its officers, agents, employees, or subcontractors who will participate in the performance of any services required by this Agreement has or will have any conflict of interest, direct or indirect, with City.

5.13.2 For purposes of compliance with IC 36-1-21, Contractor certifies and warrants to City that Contractor, or a person who wholly or partially owns Contractor, is not a relative, as that term is defined by IC 36-1-21-3, of an elected official of Noblesville, Indiana.

5.14 Non-contingent Fees. Contractor warrants that no person or selling agency has been employed or retained to solicit or secure this Agreement upon an agreement or understanding for a commission, percentage, brokerage, or contingent fee, excepting bona fide employees. For breach or violation of this warranty City shall have the right to annul this Agreement without liability or in its discretion to deduct from the Agreement price or consideration, or otherwise recover, the full amount of such commission, percentage, brokerage, or contingent fee.

5.15 Force Majeure. In the event that either party is unable to perform any of its obligations under this Agreement – or to enjoy any of its benefits – because of fire, explosion, power blackout, natural disaster, strike, embargo, labor disputes, war, terrorism, acts of God, acts or decrees of governmental bodies or other causes beyond such party's reasonable control (hereinafter referred to as Force Majeure Event), the party who has been so affected shall immediately give notice to the other and shall take commercially reasonable actions to resume performance. Upon receipt of such notice, all obligations under this Agreement shall immediately be suspended except for payment obligations with respect to service already provided. If the period of nonperformance exceeds sixty (60) days from the receipt of the Force Majeure Event, the party whose ability to perform has not been so affected may, by giving written notice, terminate this Agreement.

5.16 Applicable Laws; Forum.

5.16.1 Contractor agrees to comply with all applicable federal, state and local laws, rules, regulations or ordinances, and all provisions required thereby to be included in this Agreement are hereby incorporated by reference. This includes, but is not limited to, the Federal Civil Rights Act of 1964 and, if applicable, the Drug-Free Workplace Act of 1988. The enactment of any state or federal statute or the promulgation of regulations thereunder after execution of this Agreement shall be reviewed by City and Contractor to determine whether the provisions of the Agreement require formal modification.

- 5.16.2 This Agreement shall be construed in accordance with the laws of the State of Indiana, and by all applicable Municipal Ordinance or Codes of the City of Noblesville, County of Hamilton. Suit, if any, shall be brought in the State of Indiana, County of Hamilton.
- 5.17 Waiver. City's delay or inaction in pursuing its remedies set forth in this Agreement, or available by law, shall not operate as a waiver of any of City's rights or remedies.
- 5.18 Severability. If any provision of this Agreement is held to be invalid, illegal, or unenforceable by a court of competent jurisdiction, the provision shall be stricken, and all other provisions of this Agreement which can operate independently of such stricken provisions shall continue in full force and effect.
- 5.19 Attorneys' Fees. Contractor shall be liable to City for reasonable attorneys' fees incurred by City if it is the prevailing party in connection with the collection of any damages arising from the negligent or wrongful act or omission of Contractor, or from Contractor's failure to fulfill any provisions or responsibility provided herein.
- 5.20 Successors and Assigns. City and Contractor each binds itself and its partners, successors, executors, administrators and assigns to the other party of this Agreement and to the partners, successors, executors, administrators and assigns of such other party, in respect to all covenants of this Agreement; except as otherwise provided herein, Contractor shall not assign, sublet or transfer its interest in this Agreement without the written consent of City. Nothing herein shall be construed as creating any personal liability on the part of any officer or agent of City or the Contractor.
- 5.21 Authority to Bind Contractor. Notwithstanding anything in this Agreement to the contrary, the signatory for Contractor represents that he/she has been duly authorized to execute agreements on behalf of Contractor and has obtained all necessary or applicable approval from the home office of Contractor to make this Agreement fully binding upon Contractor when his/her signature is affixed and accepted by City.
- 5.22 Debarment and Suspension
- 5.22.1 Contractor certifies, by entering into this Agreement, that neither it nor its principals are presently debarred, suspended, proposed for debarment, declared ineligible, or voluntarily excluded from or ineligible for participation in any Federal assistance program by any Federal department or agency, or by any department, agency or political subdivision of the State of Indiana. The term "principal" for purposes of this Agreement means an officer, director, owner, partner, key employee, or other person with primary management or supervisory responsibilities, or a person who has a critical influence on or substantive control over the operations of Contractor.
- 5.22.2 Contractor certifies, by entering into this Agreement, that it does not engage in investment activities in Iran as more particularly described in IC 5-22-16.5.
- 5.22.3 Contractor shall provide immediate written notice to City if, at any time after entering into this Agreement, Contractor learns that its certifications were

erroneous when submitted, or Contractor is debarred, suspended, proposed for debarment, declared ineligible, has been included on a list or received notice of intent to include on a list created pursuant to IC 5-22-16.5, voluntarily excluded from or becomes ineligible for participation in any Federal assistance program. Any such event shall be cause for termination of this Agreement as provided herein.

5.22.4 Contractor shall not subcontract with any party which is debarred or suspended or is otherwise excluded from or ineligible for participation in any Federal assistance programs by any Federal department or agency, or by any department, agency or political subdivision of the State of Indiana.

5.23 Compliance With E-Verify Program. Pursuant to IC 22-5-1.7, Contractor shall enroll in and verify the work eligibility status of all newly hired employees of Contractor through the E-Verify Program (“Program”). Contractor is not required to verify the work eligibility status of all newly hired employees through the Program if the Program no longer exists.

5.23.1 Contractor and its subcontractors shall not knowingly employ or contract with an unauthorized alien or retain an employee or contract with a person that Contractor or its subcontractor subsequently learns is an unauthorized alien. If Contractor violates this Section 5.23, City shall require Contractor to remedy the violation not later than thirty (30) days after City notifies Contractor. If Contractor fails to remedy the violation within the thirty (30) day period, City shall terminate the contract for breach of contract. If City terminates the contract, Contractor shall, in addition to any other contractual remedies, be liable to City for actual damages. There is a rebuttable presumption that Contractor did not knowingly employ an unauthorized alien if Contractor verified the work eligibility status of the employee through the Program.

5.23.2 If Contractor employs or contracts with an unauthorized alien but City determines that terminating the contract would be detrimental to the public interest or public property, City may allow the contract to remain in effect until City procures a new contractor.

5.23.3 Contractor shall, prior to performing any work, require each subcontractor to certify to Contractor that the subcontractor does not knowingly employ or contract with an unauthorized alien and has enrolled in the Program. Contractor shall maintain on file a certification from each subcontractor throughout the duration of the Project. If Contractor determines that a subcontractor is in violation of this Section 5.23, Contractor may terminate its contract with the subcontractor for such violation.

5.23.4 Pursuant to IC 22-5-1.7 a fully executed affidavit affirming that the business entity does not knowingly employ an unauthorized alien and confirming Contractors enrollment in the Program, unless the Program no longer exists, shall be filed with City prior to the execution of this Agreement. This Agreement shall not be deemed fully executed until such affidavit is filed with the City.

IN WITNESS WHEREOF, the parties hereto have executed this Agreement on the dates subscribed below.

American Structurepoint, Inc. ("Contractor")

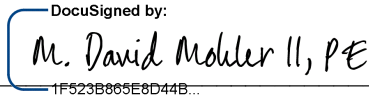
By:  _____
1F523B885E8D44B...

Date: 4/25/2024

Printed: M. David Mohler II, PE

Title: Vice President

Approved by the Board of Public Works and Safety of the City of Noblesville this _____ day of _____ 202_.

JACK MARTIN, PRESIDENT

JOHN DITSLEAR, MEMBER

LAURIE DYER, MEMBER

ROBERT J. ELMER, MEMBER

RICK L. TAYLOR, MEMBER

ATTEST:

EVELYN L. LEES, CLERK
CITY OF NOBLESVILLE, INDIANA

E-Verify Affidavit

Pursuant to Indiana Code 22-5-1.7-11, the Contractor entering into a contract with the City is required to enroll in and verify the work eligibility status of all its newly hired employees through the E-Verify program. The Contractor is not required to verify the work eligibility status of all its newly hired employees through the E-Verify program if the E-Verify program no longer exists.

The undersigned, on behalf of the Contractor, being first duly sworn, deposes and states that the Contractor does not knowingly employ an unauthorized alien. The undersigned further affirms that, prior to entering into its contract with the City, the undersigned Contractor will enroll in and agrees to verify the work eligibility status of all its newly hired employees through the E-Verify program.

(Contractor): American Structurepoint, Inc.

By (Written Signature): *Benjamin W. Borcharding*

(Printed Name): Benjamin W. Borcharding

(Title): Chief Operating Officer

Important - Notary Signature and Seal Required in the Space Below

STATE OF Indiana

SS:

COUNTY OF Marion

Subscribed and sworn to before me this 24 day of April, 2024.

My commission expires: September 25, 2030 (Signed) *Tamara Scales*

a. Residing in Marion County, State of Indiana

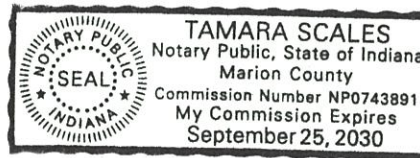

Exhibit A

PART 1 – BASIC SERVICES

1. LS 2 Pump Design Project

- A. Develop plans and technical specifications for replacement of the three (3) existing dry-pit pumps (40 HP), valves, and associated piping in the lower level of LS 2. Replacement pumps will be purchased by the CITY in a separate contract. The selected pumps are included as Attachment 1. Plans will be developed utilizing existing PDF as-built drawings provided by the CITY dated November 15, 1971, and November 2000, respectively.
- B. Design will include suggested piping modifications based upon use of pumps included in Attachment 1. The installed orientation of the pumps will be determined during the design phase following coordination with the CITY.
- C. Determine best suction/discharge orientation to allow for pump removal/maintenance and to limit discharge pipe modifications. Existing valves on suction side of pumps will be replaced with new valves. Existing valves on discharge side of pumps will remain and will be reused.
- D. Evaluate location of new pumps to ensure ability to remove pumps and other equipment (pipe and valves) for operation and maintenance activities.
- E. Design Phase services assume that new lifting eyes will be required. The structural scope of services includes the specification and detailing of (3) new lifting eyes and their connections to the existing elevated concrete floor, including analysis of the existing floor for the new imposed lifting loads. Design of lifting eyes will utilize pump weights of selected pumps and CITY-selected manual hoist system. Additionally, it includes the anchorage detail for the new ladder and safety cage to the existing concrete wall.
- F. Provide safety cage for man access from main floor to mechanical room level (Mid-Level) and Pump Room (Lower Level) utilizing existing 3'-6" x 4'-0" opening in southwest corner of existing Pump Station Building. Coordinate attachment of new safety cage to existing structure and provide anchor design. Safety cage to be turn-key product, or designed, detailed, and specified by others.
- G. CONTRACTOR will prepare a preliminary (50%) submittal for CITY review and comments. A 50% Design meeting will be held to discuss CITY's review comments.
- H. CONTRACTOR will prepare a final (90%) submittal for CITY review and comments. A 90% Design meeting will be held to discuss CITY's review comments.
- I. CONTRACTOR will utilize CITY-provided front-end specifications for the bid documents. Structural specifications required for the project will be "sheet specs" and included on structural drawing sheets, as necessary. CONTRACTOR assumes development of one (1) bid package.
- J. Final plans will include all items to be replaced as part of Project. The CITY indicated that certain items of the Project will be self-performed by the CITY. All items to be self-performed by the CITY will be indicated as "WORK BY OTHERS" in the design plans.

- K. Design will not include electrical and/or instrumentation and controls (I&C) modifications. Existing electrical equipment and I&C equipment will be reused for the new pumps' installation. However, CONTRACTOR will coordinate with the manufacturer's representative for the new pumps to establish that they can be reused. If it is determined that the existing variable frequency drives (VFDs) or other electrical/control equipment must be replaced as part of the Project, CONTRACTOR will work with an electrical and I&C subconsultant to include those design elements in the Project. Additional fees for the additional services will be established prior to initiating this work.
- L. It is assumed that no permits are required as part of the LS 2 Pump Replacement design.

2. LS 2 48-Inch Interceptor Project

A. CONTRACTOR shall perform the following Services as a continuation of the 95% Design effort already completed, per the executed agreement between CONTRACTOR and CITY effective as of May 28, 2019 and Amendment No. 1 effective as of December 3, 2019. Services will include survey and process design. The Services will include Final Design for the following Project components: 1) 48-inch parallel interceptor, 2) Diversion Structure, and 3) Site Improvements. Bidding and Construction Administration services for the above-noted components will be covered under a separate existing on-call contract with the CITY:

- 1) Topographic Survey: CONTRACTOR will provide easement staking for tree clearing:
 - a. Establish three (3) horizontal control points.
 - a. Set and reference control for use during construction.
 - b. Establish vertical control.
 - a. Set two (2) temporary benchmarks on site for use during construction.
 - c. Field Stake existing 30' easement and proposed 20' easement east for clearing and grubbing with lath.
 - d. Approximate staking limits (see aerial below)



- 2) Modify Existing Lift Station No. 2 Improvements Plan Set: CONTRACTOR will modify existing Lift Station No. 2 Improvements plan set to eliminate all other project requirements except for the 48-inch interceptor and associated improvements. Modifications will include, but are not limited to, development of the following: cover sheet, index and general information, benchmark and control plan, existing site plan, demolition sheets, grading plan, yard piping plan, plan and profile of proposed 48-inch interceptor, plan and profile of proposed 15-inch storm sewer, general details, and CITY details. Proposed 48-inch interceptor will be installed along the proposed alignment of the 42-inch interceptor included in the original design and will be designed with the capability of conveying all current and future build-out flows to allow CITY ability to abandon existing 27-inch interceptor in the future. Design will include replacement of existing 27-inch interceptor between the existing Junction Chamber and the existing manhole to the south to redirect flow from the existing 12-inch north to the Junction Chamber to allow abandonment of existing 27-inch interceptor to Lift Station No. 2.
- 3) 48-inch Parallel Interceptor: CONTRACTOR will modify the previous design of the proposed 48-inch parallel interceptor (1,470 LF +/-) between existing manhole SA-NEINTP-0040 and the existing wet well. Design will include modifications to existing manhole SA-NEINTP-0040 and connection of existing 27-inch interceptor to proposed 48-inch interceptor at the proposed Diversion Structure. All flow will continue to be conveyed by existing 27-inch interceptor connection into north wall of existing wet well.
- 4) Diversion Structure: CONTRACTOR will modify the previous design to include a diversion structure that will combine the flows from the existing 27-inch interceptor and proposed 48-inch interceptor. Diversion Structure will include a 48-inch interceptor stub to the north to allow for future extension of 48-inch interceptor to the future wastewater treatment plant (WWTP) site.
- 5) LS 2 Site Improvements: CONTRACTOR will complete the design of the associated LS 2 site improvements. Design will include the following:
 - i. Site Improvements: Site improvements will include the following:
 - a. New 6-foot chain link fence and manual access gate(s) for fence segments on north side of LS 2 site to be removed and replaced as part of this project.
 - b. New asphalt access drives and curb and gutter off 10th Street and access to LS 2 site.
 - c. New asphalt and curb and gutter to replace damaged sections resulting from construction activities along the existing access drive to the local business (Reliable Fab and Manufacturing).
 - d. Site grading, seeding and plantings (if required).
 - ii. Site Piping: New site piping will include the following:
 - a. 27-inch interceptor pipe to be tied into the south wall of the proposed Diversion Structure to connect into the north wall of the existing sanitary manhole.
 - b. 48-inch interceptor pipe to be tied into the east wall of the proposed Diversion Structure.
 - c. 48-inch interceptor sewer to be stubbed out of the north end of the proposed Diversion Structure and capped for future connection to extend

48-inch sewer northwest to the future the future wastewater treatment plant (WWTP) site.

- d. Relocation of existing 15-inch storm sewer east to new discharge location including new headwall and riprap.
- 6) Project Manual and Specifications: CONTRACTOR will prepare a Project Manual that includes front-end documents and Technical Specifications in MasterFormat (48 Division) specifications. CITY will provide CONTRACTOR with standard required front-end documents.
- 7) Meetings with CITY to Discuss Design: CONTRACTOR will submit 50% and 90% Design information to the CITY for CITY review and will meet with CITY to discuss CITY's review comments. CONTRACTOR will update design information based on 50% and 90% review meetings.
- 8) CONTRACTOR's Opinion of Probable Construction Costs: CONTRACTOR will prepare CONTRACTOR's opinions of probable Construction Cost on the basis of CONTRACTOR's experience and qualifications and represent CONTRACTOR's best judgment as an experienced and qualified professional generally familiar with the construction industry and will follow ACEC guidelines. However, since CONTRACTOR has no control over the cost of labor, materials, equipment, or services furnished by others, or over contractors' methods of determining prices, or over competitive bidding or market conditions, CONTRACTOR cannot and does not guarantee that proposals, bids, or actual Construction Cost will not vary from opinions of probable Construction Cost prepared by CONTRACTOR.
- 9) IDEM Construction Permit: CONTRACTOR will prepare and submit an IDEM Construction Permit application and coordinate with IDEM to complete the permitting process for this project. All associated permitting costs will be the responsibility of the CITY.

3. Notes:

- A. In the event that the Work designed or specified by CONTRACTOR is to be performed or furnished under more than one prime contract, or if CONTRACTOR's services are to be separately sequenced with the work of one or more prime CONTRACTORS (such as in the case of fast-tracking), CITY and CONTRACTOR shall, prior to commencement of the Final Design Phase, develop a schedule for performance of CONTRACTOR's services during the Final Design, Bidding or Negotiating, Construction, and Post-Construction Phases in order to sequence and coordinate properly such services as are applicable to the work under such separate prime contracts. This schedule is to be prepared and included in or become an amendment to Exhibit A whether or not the work under such contracts is to proceed concurrently.
- B. The number of prime contracts for Work designed or specified by CONTRACTOR upon which the CONTRACTOR's compensation has been established under this Agreement is two (2). If more prime contracts are awarded, CONTRACTOR shall be entitled to an equitable increase in its compensation under this Agreement.

4. Attachment 1 - Cut sheet information for Hidrostral F10K Pumps (40 HP) dated April 8, 2019

PART 2 – ADDITIONAL SERVICES

A2.01 Additional Services Requiring CITY's Written Authorization

- A. If authorized in writing by CITY, CONTRACTOR shall furnish or obtain from others Additional Services of the types listed below.
1. Preparation of applications and supporting documents (in addition to those furnished under Basic Services) for private or governmental grants, loans, or advances in connection with the Project; preparation or review of environmental assessments and impact statements; review and evaluation of the effects on the design requirements for the Project of any such statements and documents prepared by others; and assistance in obtaining approvals of authorities having jurisdiction over the anticipated environmental impact of the Project.
 2. Services to make measured drawings of or to investigate existing conditions or facilities, or to verify the accuracy of drawings or other information furnished by CITY or others.
 3. Services resulting from significant changes in the scope, extent, or character of the portions of the Project designed or specified by CONTRACTOR or its design requirements including, but not limited to, changes in size, complexity, CITY's schedule, character of construction, or method of financing; and revising previously accepted studies, reports, Drawings, Specifications, or Contract Documents when such revisions are required by changes in Laws and Regulations enacted subsequent to the Effective Date of this Agreement or are due to any other causes beyond CONTRACTOR's control.
 4. Services required as a result of CITY's providing incomplete or incorrect Project information to CONTRACTOR.
 5. Undertaking investigations and studies including, but not limited to, detailed consideration of operations, maintenance, and overhead expenses; the preparation of feasibility studies, cash flow and economic evaluations, rate schedules, and appraisals; assistance in obtaining financing for the Project; evaluating processes available for licensing, and assisting CITY in obtaining process licensing; detailed quantity surveys of materials, equipment, and labor; and audits or inventories required in connection with construction performed by CITY.
 6. Furnishing services of CONTRACTOR's Consultants for other than Basic Services.
 7. Preparing for, coordinating with, participating in and responding to structured independent review processes, including, but not limited to, construction management, cost estimating, project peer review, value engineering, and constructability review requested by CITY; and performing or furnishing services required to revise studies, reports, Drawings, Specifications, or other Bidding Documents as a result of such review processes.
 8. Providing assistance in responding to the presence of any Constituent of Concern at the Site, in compliance with current Laws and Regulations.
 9. Preparing and furnishing CITY Record Drawings showing appropriate record information based on Project annotated record documents received from CONTRACTOR.
 10. Preparation of operation and maintenance manuals.

11. Preparing to serve or serving as a consultant or witness for CITY in any litigation, arbitration, or other dispute resolution process related to the Project.
12. Providing more extensive services required to enable CONTRACTOR to issue notices or certifications requested by CITY.
13. Other services performed or furnished by CONTRACTOR not otherwise provided for in this Agreement.

PART 3 – SCHEDULE

1. The schedule for rendering services is as follows:

LS 2 Pump Replacement Project:

- A. Complete Design Phase Services within 90 days from Notice to Proceed.

48-Inch Interceptor Project:

- A. 50% construction documents submittal to CITY for review July 19, 2024
- B. Final construction documents submittal to IDEM for construction permit: August 2, 2024
- C. Final bid documents (contingent upon IDEM approval): September 6, 2024

PUMP	C	VD	VS
F10K-SS/-HD	13.39in [340mm]	33.07in [840mm]	22.83in [580mm]
F10K-MD	12.72in [323mm]	32.40in [823mm]	22.17in [563mm]

MOTOR SIZE	APPROX. LIFTING * WEIGHT (LBS.)
FE4A6	1,004
FE4C4	1,070
FE4S6	1,355
FE4T4	1,244
FE5B4	1,516
FE5V4	1,756
FEXQ8	735
FEXW6	848
FEXW8	788

BILL OF MATERIALS			
ITEM	QTY.	DESCRIPTION	APPROX. WEIGHT
1	1	HIDROSTAND™ (250x300)	700 LBS.
2	1	PUMP	SEE TABLE

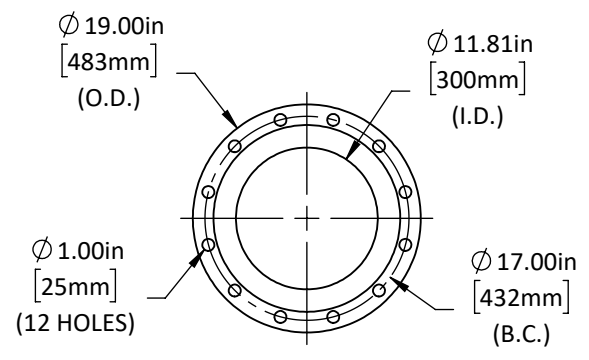

12" SUCTION FLANGE
(HIDROSTAND™)
(SCALE: 1:16)

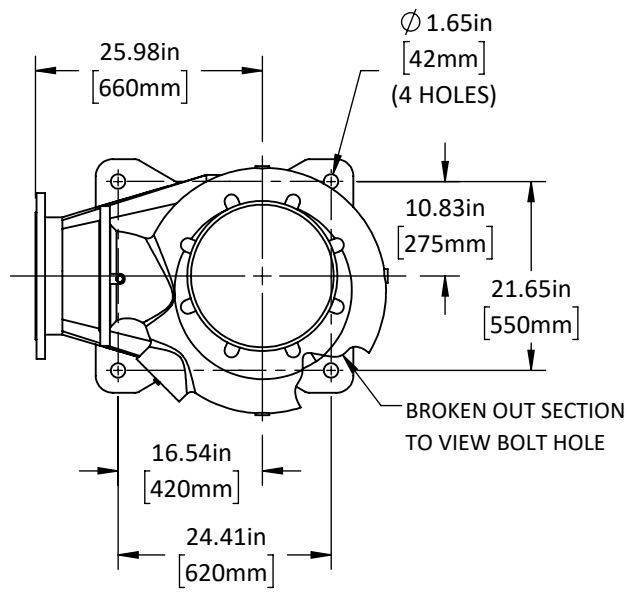

SECTION A-A
(HIDROSTAND™ ANCHOR BOLT PLAN)

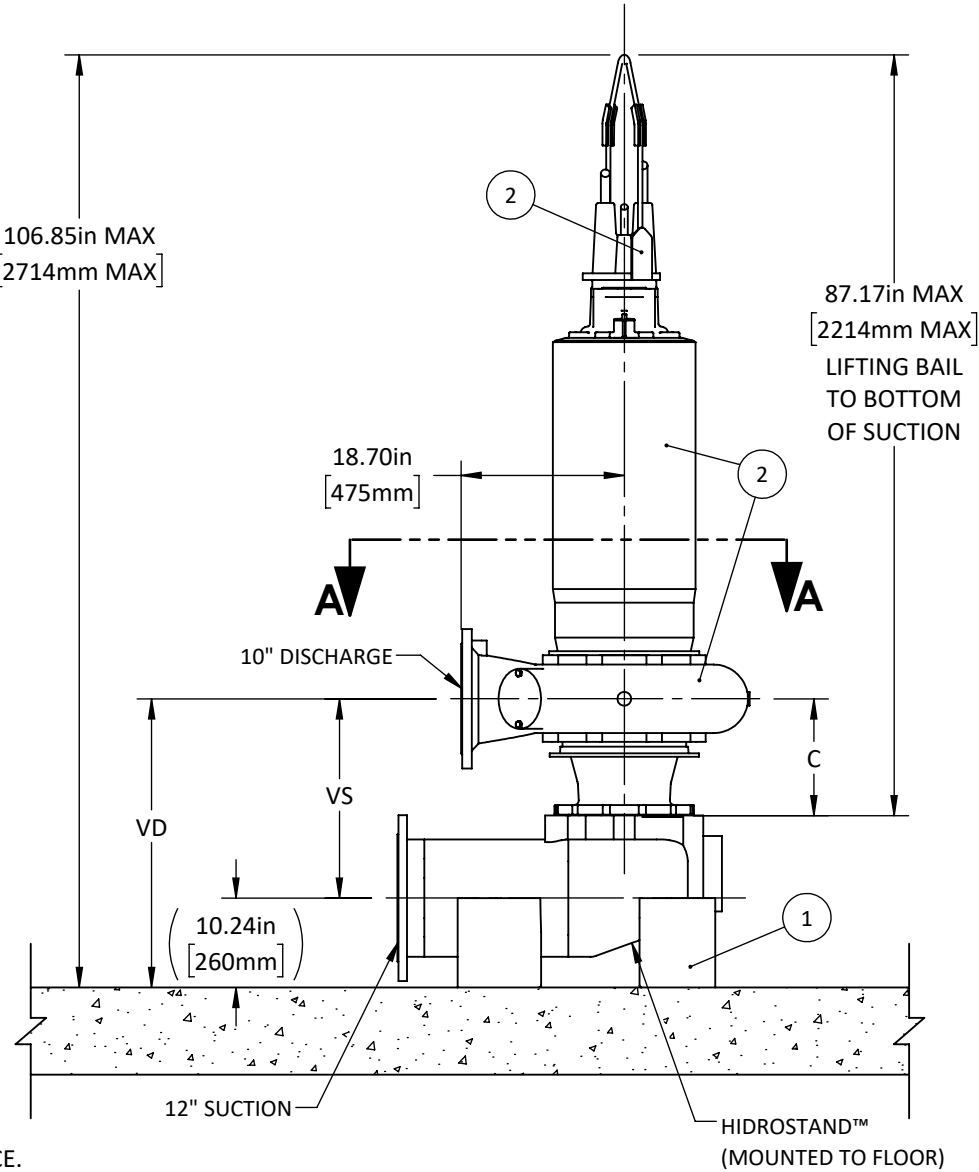

SIDE VIEW

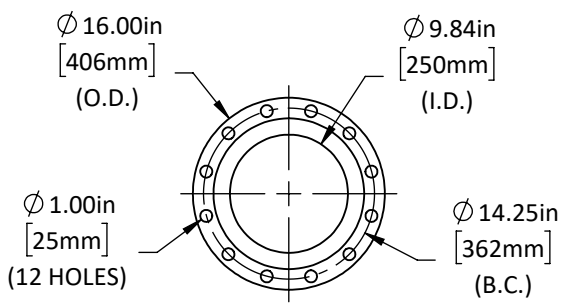

10" DISCHARGE FLANGE
(SCALE: 1:16)

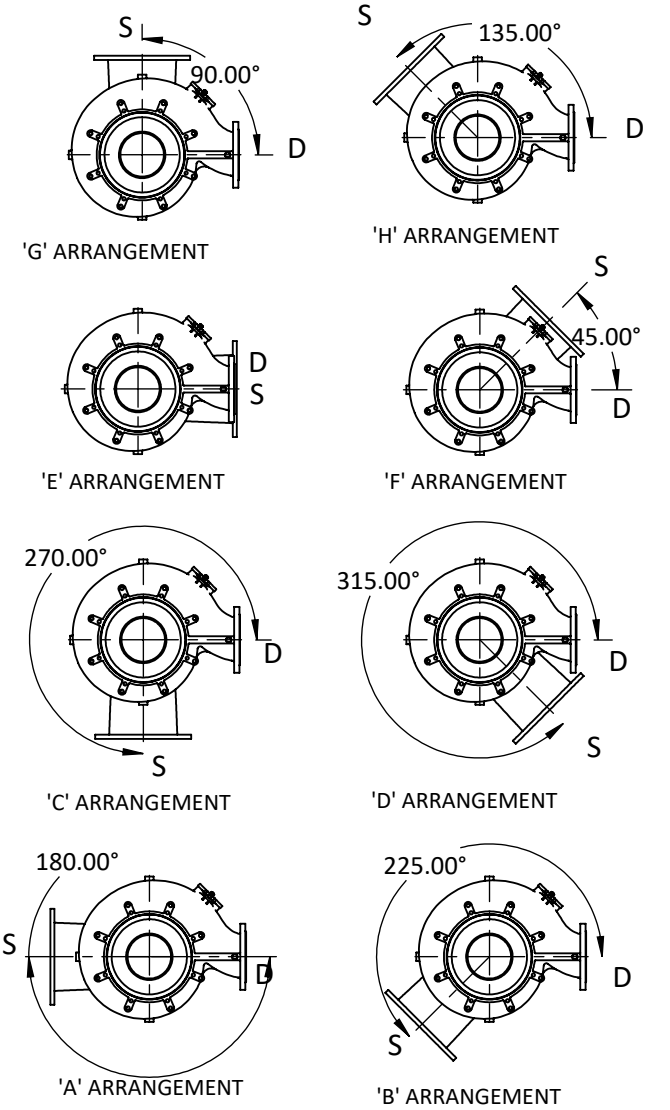

SUCTION AND DISCHARGE ARRANGEMENTS

- NOTES:**
1. PUMP AND ACCESSORIES ARE DESIGNED FOR CONTINUOUS SERVICE.
 2. PUMP SIZE, MODEL AND SERIAL NUMBER MUST BE SPECIFIED WHEN ORDERING SPARE PARTS.
 3. CLOCKWISE ROTATION VIEWED FROM SHAFT END; CCW IS NOT AVAILABLE.
 4. SUCTION AND DISCHARGE FLANGE MATE WITH CLASS 125 & 150 FLANGES.
 5. ITEM 2 INCLUDES MOTOR AND LIFTING BAIL.

F6K™
F10K-SS™
F10K-HD™
F10K-MD™

HIDROSTAL PUMPS
North America

DESCRIPTION: **INSTALLATION F10K-SS/-HD/-MD IMMERSIBLE/SUBMERSIBLE VERTICAL HIDROSTAND™**

REV	DATE	ZONE	DESCRIPTION	APPROVED	STANDARD MACHINE TOLERANCES UNLESS OTHERWISE SPECIFIED ALL DIMENSIONS IN INCHES	DO NOT SCALE DRAWING THIRD ANGLE PROJECTION	PROPRIETARY AND CONFIDENTIAL THE INFORMATION CONTAINED IN THIS DRAWING IS THE SOLE PROPERTY OF HIDROSTAL LLC. ANY REPRODUCTION IN PART OR AS A WHOLE WITHOUT THE WRITTEN PERMISSION OF HIDROSTAL LLC IS PROHIBITED. Copyright © 2015 Hidrostral LLC All Rights Reserved.	MODEL:	SALES ORDER:	DRAWING NUMBER:	
					// .005 TIR ↗ .005 TIR .XX ±0.02 BREAK OUTSIDE EDGES .005-.035 ⊥ .005 TIR ∠ ±.5° .XXX ±0.005 INSIDE CORNER R .035 MAX © .005 TIR √ 125 RMS X/X ±1/32 ALL DRILL & TAP DEPTHS ±0.06						INS-IS-F10K-VHS
								DRAWN BY: TES	DATE: 04/08/19	WEIGHT:	SCALE: 1:22
								CHECKED BY: TD	DWG. SIZE: B	SHEET 1 OF 1	REV.

**PURCHASE ORDER
CITY OF NOBLESVILLE
16 SOUTH 10TH STREET STE 270**

INDIANA RETAIL TAX EXEMPT
CERTIFICATE NO. 0031216070010

FEDERAL EXCISE TAX EXEMPT
356001141

**NOBLESVILLE IN 46060
PHONE: 317-776-6328
FAX: 317-776-6369**

PURCHASE ORDER NO. 240192

THIS NUMBER MUST APPEAR ON INVOICES, A/P VOUCHER, DELIVERY MEMO, PACKING SLIPS, SHIPPING LABELS AND ANY CORRESPONDENCE.

SHIP TO:

TO
VENDOR # 534
AMERICAN STRUCTUREPOINT INC
9025 RIVER ROAD
SUITE 200
INDIANAPOLIS IN 46240

ATTN:

DATE 04/26/2024		DEPARTMENT UTILITIES			SHIP TO ARRIVE BY		
APPROPRIATION NUMBER	QUANTITY	UNIT	DESCRIPTION	PROJECT #	UNIT PRICE	AMOUNT	
311033313.100	1.0		SERVICE AGREEMENT FOR LS2		108900.00	108900.00	

SHIP VIA

TOTAL

108900.00

SHIPPING INSTRUCTIONS

- * SHIP PREPAID
- * C.O.D. SHIPMENTS CANNOT BE ACCEPTED
- * PURCHASE ORDER NUMBER MUST APPEAR ON ALL SHIPPING LABELS.
- * THIS ORDER ISSUED IN COMPLIANCE WITH CHAPTER 99, ACTS 1945 AND ACTS AMENDATORY THEREOF AND SUPPLEMENTAL THERETO.

PAYMENT

- * A/P VOUCHER CANNOT BE APPROVED FOR PAYMENT UNLESS THE P.O. NUMBER IS MADE A PART OF THE VOUCHER AND EVERY INVOICE AND VOUCHER HAS THE PROPER SWORN AFFIDAVIT ATTACHED.
- * I HEREBY CERTIFY THAT THERE IS AN UNOBLIGATED BALANCE IN THIS APPROPRIATION SUFFICIENT TO PAY FOR THE ABOVE ORDER.

ORDERED BY _____

TITLE _____ CONTROLLER _____

ORIGINAL - VENDOR'S COPY

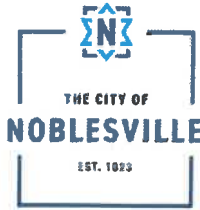

FINANCE & ACCOUNTING

Funding Verification/Encumbrance Request Form

Date to be submitted to BoW/Park Board: 5/14/24 (put N/A if not submitting to BoW/Park Board)

Vendor name: American Structurepoint, Inc. 534

Vendor Address: 9025 River Road, Suite 200, Indianapolis, IN 46240

Brief description of purchase: Service Agreement for LS2

Source of Funding:

- Current Year Operational Budget
- Subsequent Year Operational Budget¹
- Funding not yet finalized (attach explanation)²
- Loan or debt proceeds
- Non-Appropriated Fund³

Fund #	311
Department #	033
Project # (NA if no project #)	313.100 <i>NO project</i>
Expense Object #	Amount
#1	\$ 108,900.00
#2	
#3	

- 1) This option may only be selected AFTER the adoption of the subsequent year budget. OFA will create a PO after the start of the next year. If contract details change in between form submission and the start of the year, contact OFA Staff.
- 2) This option may only be selected in unusual circumstances. An additional FVF will need to be submitted to OFA once funding source has been determined. OFA will not create a PO until this follow-up form has been submitted.
- 3) These funds are not appropriated through the annual budget process. They include but are not limited to grant funds and impact fee funds.

Are you requesting that a Purchase Order (PO) be created for this expenditure?

- Yes Select for all purchases/contracts that will not be paid immediately
- No Select ONLY if department plans to initiate payment immediately

Additional Comments: _____

The Department certifies that sufficient appropriation authority exists in the stated fund and expense series to obligate the expense for future payment.

Department Director

Jonathan Mirgeaux
Digitally signed by Jonathan Mirgeaux
DN: cn=Jonathan Mirgeaux, o=City of Noblesville, ou=City of Noblesville, email=J.Mirgeaux@noblesville.in.gov

(Signature)

Jonathan Mirgeaux

(Printed Name)

4/26/24

(Date)

Please email completed form to OFAbudget@noblesville.in.gov

FOR OFFICE OF FINANCE AND ACCOUNTING USE ONLY

OFA Action Taken

- Purchase Order Created
- Reviewed Availability of funds (Contract/Purchase of over \$50k or paid with debt proceeds only)
OFA Signature Ian Zelgowski Digitally signed by Ian Zelgowski
Date: 2024.04.26 15:04:44 -04'00'

PO # (if applicable): 240192

- No Action Taken (Department should still include this form in purchase/contract approval submission)

Comments: _____

Initials: CM

Date: 4/26/24



CERTIFICATE OF LIABILITY INSURANCE

DATE (MM/DD/YYYY)

5/6/2024

THIS CERTIFICATE IS ISSUED AS A MATTER OF INFORMATION ONLY AND CONFERS NO RIGHTS UPON THE CERTIFICATE HOLDER. THIS CERTIFICATE DOES NOT AFFIRMATIVELY OR NEGATIVELY AMEND, EXTEND OR ALTER THE COVERAGE AFFORDED BY THE POLICIES BELOW. THIS CERTIFICATE OF INSURANCE DOES NOT CONSTITUTE A CONTRACT BETWEEN THE ISSUING INSURER(S), AUTHORIZED REPRESENTATIVE OR PRODUCER, AND THE CERTIFICATE HOLDER.

IMPORTANT: If the certificate holder is an **ADDITIONAL INSURED**, the policy(ies) must have **ADDITIONAL INSURED** provisions or be endorsed. If **SUBROGATION IS WAIVED**, subject to the terms and conditions of the policy, certain policies may require an endorsement. A statement on this certificate does not confer rights to the certificate holder in lieu of such endorsement(s).

PRODUCER Edgewood Partners Insurance Agency 3780 Mansell Rd. Ste. 370 Alpharetta GA 30022		CONTACT NAME: Rebecca Egan PHONE (A/C. No. Ext): 770-552-4225 FAX (A/C. No.): 770-552-4225 E-MAIL ADDRESS: ACECcertificates@greyling.com	
		INSURER(S) AFFORDING COVERAGE	
		INSURER A: Valley Forge Insurance Company	NAIC # 20508
		INSURER B: The Continental Insurance Company	35289
		INSURER C: National Fire Insurance Co of Hartford	20478
		INSURER D: Travelers Casualty & Surety Co America	31194
		INSURER E: Transportation Insurance Company	20494
		INSURER F:	

COVERAGES **CERTIFICATE NUMBER:** 1016850842 **REVISION NUMBER:**

THIS IS TO CERTIFY THAT THE POLICIES OF INSURANCE LISTED BELOW HAVE BEEN ISSUED TO THE INSURED NAMED ABOVE FOR THE POLICY PERIOD INDICATED. NOTWITHSTANDING ANY REQUIREMENT, TERM OR CONDITION OF ANY CONTRACT OR OTHER DOCUMENT WITH RESPECT TO WHICH THIS CERTIFICATE MAY BE ISSUED OR MAY PERTAIN, THE INSURANCE AFFORDED BY THE POLICIES DESCRIBED HEREIN IS SUBJECT TO ALL THE TERMS, EXCLUSIONS AND CONDITIONS OF SUCH POLICIES. LIMITS SHOWN MAY HAVE BEEN REDUCED BY PAID CLAIMS.

INSR LTR	TYPE OF INSURANCE	ADDL INSD	SUBR WVD	POLICY NUMBER	POLICY EFF (MM/DD/YYYY)	POLICY EXP (MM/DD/YYYY)	LIMITS
A	<input checked="" type="checkbox"/> COMMERCIAL GENERAL LIABILITY <input type="checkbox"/> CLAIMS-MADE <input checked="" type="checkbox"/> OCCUR \$1M/\$1M/\$1M GEN'L AGGREGATE LIMIT APPLIES PER: <input type="checkbox"/> POLICY <input checked="" type="checkbox"/> PRO-JECT <input checked="" type="checkbox"/> LOC OTHER:			6050367892	11/1/2023	11/1/2024	EACH OCCURRENCE \$ 1,000,000 DAMAGE TO RENTED PREMISES (Ea occurrence) \$ 1,000,000 MED EXP (Any one person) \$ 15,000 PERSONAL & ADV INJURY \$ 1,000,000 GENERAL AGGREGATE \$ 2,000,000 PRODUCTS - COMP/OP AGG \$ 2,000,000 \$
E	<input checked="" type="checkbox"/> AUTOMOBILE LIABILITY <input checked="" type="checkbox"/> ANY AUTO <input type="checkbox"/> OWNED AUTOS ONLY <input type="checkbox"/> SCHEDULED AUTOS <input checked="" type="checkbox"/> HIRED AUTOS ONLY <input checked="" type="checkbox"/> NON-OWNED AUTOS ONLY			6050364572	11/1/2023	11/1/2024	COMBINED SINGLE LIMIT (Ea accident) \$ 1,000,000 BODILY INJURY (Per person) \$ BODILY INJURY (Per accident) \$ PROPERTY DAMAGE (Per accident) \$ \$
B	<input checked="" type="checkbox"/> UMBRELLA LIAB <input checked="" type="checkbox"/> OCCUR <input type="checkbox"/> EXCESS LIAB <input type="checkbox"/> CLAIMS-MADE <input type="checkbox"/> DED <input checked="" type="checkbox"/> RETENTION \$ 10,000			6050364555	11/1/2023	11/1/2024	EACH OCCURRENCE \$ 10,000,000 AGGREGATE \$ 10,000,000 \$
C	<input checked="" type="checkbox"/> WORKERS COMPENSATION AND EMPLOYERS' LIABILITY ANY PROPRIETOR/PARTNER/EXECUTIVE OFFICER/MEMBER EXCLUDED? <input type="checkbox"/> Y <input checked="" type="checkbox"/> N (Mandatory in NH) If yes, describe under DESCRIPTION OF OPERATIONS below		N/A	650364569	11/1/2023	11/1/2024	<input checked="" type="checkbox"/> PER STATUTE <input type="checkbox"/> OTH-ER E.L. EACH ACCIDENT \$ 1,000,000 E.L. DISEASE - EA EMPLOYEE \$ 1,000,000 E.L. DISEASE - POLICY LIMIT \$ 1,000,000
D	Professional Liability incl. Pollution Liability			107806802	5/29/2024	5/29/2025	Per Claim \$5,000,000 Aggregate \$5,000,000

DESCRIPTION OF OPERATIONS / LOCATIONS / VEHICLES (ACORD 101, Additional Remarks Schedule, may be attached if more space is required)
 Any person or organization, as required by written contract or agreement requiring insurance, is included as additional insured with respect to the General Liability and Automobile Liability policies. Coverage on the General Liability and Automobile policies is primary and non-contributory where required by written contract or agreement. A waiver of subrogation in favor of any person or organization, signed prior to a loss, as required by written contract or agreement requiring insurance, applies with respect to the General Liability, Automobile Liability and Employers Liability policies. Umbrella is follow form.
 Re: LS2 Pump Design 42-inch interceptor. ASI project #2022.02881.
 City of Noblesville is named as an Additional Insured with respects to General Liability where required by written contract.

CERTIFICATE HOLDER City of Noblesville 16 S. 10th St., Noblesville, IN 46060	CANCELLATION SHOULD ANY OF THE ABOVE DESCRIBED POLICIES BE CANCELLED BEFORE THE EXPIRATION DATE THEREOF, NOTICE WILL BE DELIVERED IN ACCORDANCE WITH THE POLICY PROVISIONS. AUTHORIZED REPRESENTATIVE 
--	--

© 1988-2015 ACORD CORPORATION. All rights reserved.



CERTIFICATE OF LIABILITY INSURANCE

DATE (MM/DD/YYYY)

2/21/2024

THIS CERTIFICATE IS ISSUED AS A MATTER OF INFORMATION ONLY AND CONFERS NO RIGHTS UPON THE CERTIFICATE HOLDER. THIS CERTIFICATE DOES NOT AFFIRMATIVELY OR NEGATIVELY AMEND, EXTEND OR ALTER THE COVERAGE AFFORDED BY THE POLICIES BELOW. THIS CERTIFICATE OF INSURANCE DOES NOT CONSTITUTE A CONTRACT BETWEEN THE ISSUING INSURER(S), AUTHORIZED REPRESENTATIVE OR PRODUCER, AND THE CERTIFICATE HOLDER.

IMPORTANT: If the certificate holder is an ADDITIONAL INSURED, the policy(ies) must have ADDITIONAL INSURED provisions or be endorsed. If SUBROGATION IS WAIVED, subject to the terms and conditions of the policy, certain policies may require an endorsement. A statement on this certificate does not confer rights to the certificate holder in lieu of such endorsement(s).

PRODUCER Greyling Ins. Brokerage/EPIC 3780 Mansell Rd. Ste. 370 Alpharetta GA 30022	CONTACT NAME: Rebecca Egan	
	PHONE (A/C. No. Ext): 770-552-4225	FAX (A/C. No):
E-MAIL ADDRESS: ACECcertificates@greyling.com		
INSURER(S) AFFORDING COVERAGE		NAIC #
INSURED American Structurepoint, Inc. 9025 River Road Suite #200 Indianapolis IN 46240	INSURER A: Valley Forge Insurance Company	20508
	INSURER B: The Continental Insurance Company	35289
	INSURER C: National Fire Insurance Co of Hartford	20478
	INSURER D: Travelers Casualty & Surety Co America	31194
	INSURER E: Transportation Insurance Company	20494
INSURER F:		

COVERAGES

CERTIFICATE NUMBER: 118412326

REVISION NUMBER:

THIS IS TO CERTIFY THAT THE POLICIES OF INSURANCE LISTED BELOW HAVE BEEN ISSUED TO THE INSURED NAMED ABOVE FOR THE POLICY PERIOD INDICATED. NOTWITHSTANDING ANY REQUIREMENT, TERM OR CONDITION OF ANY CONTRACT OR OTHER DOCUMENT WITH RESPECT TO WHICH THIS CERTIFICATE MAY BE ISSUED OR MAY PERTAIN, THE INSURANCE AFFORDED BY THE POLICIES DESCRIBED HEREIN IS SUBJECT TO ALL THE TERMS, EXCLUSIONS AND CONDITIONS OF SUCH POLICIES. LIMITS SHOWN MAY HAVE BEEN REDUCED BY PAID CLAIMS.

INSR LTR	TYPE OF INSURANCE	ADDL INSD	SUBR WVD	POLICY NUMBER	POLICY EFF (MM/DD/YYYY)	POLICY EXP (MM/DD/YYYY)	LIMITS
A	<input checked="" type="checkbox"/> COMMERCIAL GENERAL LIABILITY <input type="checkbox"/> CLAIMS-MADE <input checked="" type="checkbox"/> OCCUR \$1M/\$1M/\$1M GEN'L AGGREGATE LIMIT APPLIES PER: <input checked="" type="checkbox"/> POLICY <input checked="" type="checkbox"/> PRO-JECT <input type="checkbox"/> LOC OTHER:			6050367892	11/1/2023	11/1/2024	EACH OCCURRENCE \$ 1,000,000 DAMAGE TO RENTED PREMISES (Ea occurrence) \$ 1,000,000 MED EXP (Any one person) \$ 15,000 PERSONAL & ADV INJURY \$ 1,000,000 GENERAL AGGREGATE \$ 2,000,000 PRODUCTS - COMP/OP AGG \$ 2,000,000 \$
E	<input checked="" type="checkbox"/> AUTOMOBILE LIABILITY <input checked="" type="checkbox"/> ANY AUTO <input type="checkbox"/> OWNED AUTOS ONLY <input type="checkbox"/> SCHEDULED AUTOS <input checked="" type="checkbox"/> HIRED AUTOS ONLY <input checked="" type="checkbox"/> NON-OWNED AUTOS ONLY			6050364572	11/1/2023	11/1/2024	COMBINED SINGLE LIMIT (Ea accident) \$ 1,000,000 BODILY INJURY (Per person) \$ BODILY INJURY (Per accident) \$ PROPERTY DAMAGE (Per accident) \$ \$
B	<input checked="" type="checkbox"/> UMBRELLA LIAB <input checked="" type="checkbox"/> OCCUR <input type="checkbox"/> EXCESS LIAB <input type="checkbox"/> CLAIMS-MADE <input type="checkbox"/> DED <input checked="" type="checkbox"/> RETENTION \$ 10,000			6050364555	11/1/2023	11/1/2024	EACH OCCURRENCE \$ 10,000,000 AGGREGATE \$ 10,000,000 \$
C	<input checked="" type="checkbox"/> WORKERS COMPENSATION AND EMPLOYERS' LIABILITY ANY PROPRIETOR/PARTNER/EXECUTIVE OFFICER/MEMBER EXCLUDED? <input type="checkbox"/> Y <input checked="" type="checkbox"/> N (Mandatory in NH) If yes, describe under DESCRIPTION OF OPERATIONS below		N/A	WC 6 50364569	11/1/2023	11/1/2024	<input checked="" type="checkbox"/> PER STATUTE <input type="checkbox"/> OTH-ER E.L. EACH ACCIDENT \$ 1,000,000 E.L. DISEASE - EA EMPLOYEE \$ 1,000,000 E.L. DISEASE - POLICY LIMIT \$ 1,000,000
D	Professional Liability incl. Pollution Liability			107806802	5/29/2023	5/29/2024	Per Claim Aggregate 5,000,000 5,000,000

DESCRIPTION OF OPERATIONS / LOCATIONS / VEHICLES (ACORD 101, Additional Remarks Schedule, may be attached if more space is required)

Umbrella Follows Form with respects to General, Automobile & Employers Liability Policies. Waiver of Subrogation is applicable where required by written contract & allowed by law. The above referenced liability policies with the exception of workers compensation and professional liability are primary & non-contributory where required by written contract.

Re: LS2 Pump Design 42-inch interceptor. ASI project #2022.02881.

City of Noblesville is named as an Additional Insured with respects to General Liability where required by written contract.

CERTIFICATE HOLDER**CANCELLATION**

City of Noblesville
 16 S. 10th St.,
 Noblesville, IN 46060

SHOULD ANY OF THE ABOVE DESCRIBED POLICIES BE CANCELLED BEFORE THE EXPIRATION DATE THEREOF, NOTICE WILL BE DELIVERED IN ACCORDANCE WITH THE POLICY PROVISIONS.

AUTHORIZED REPRESENTATIVE

© 1988-2015 ACORD CORPORATION. All rights reserved.